

PULL ACTION FILTER CENTRIFUGE WITH BOTTOM DISCHARGE

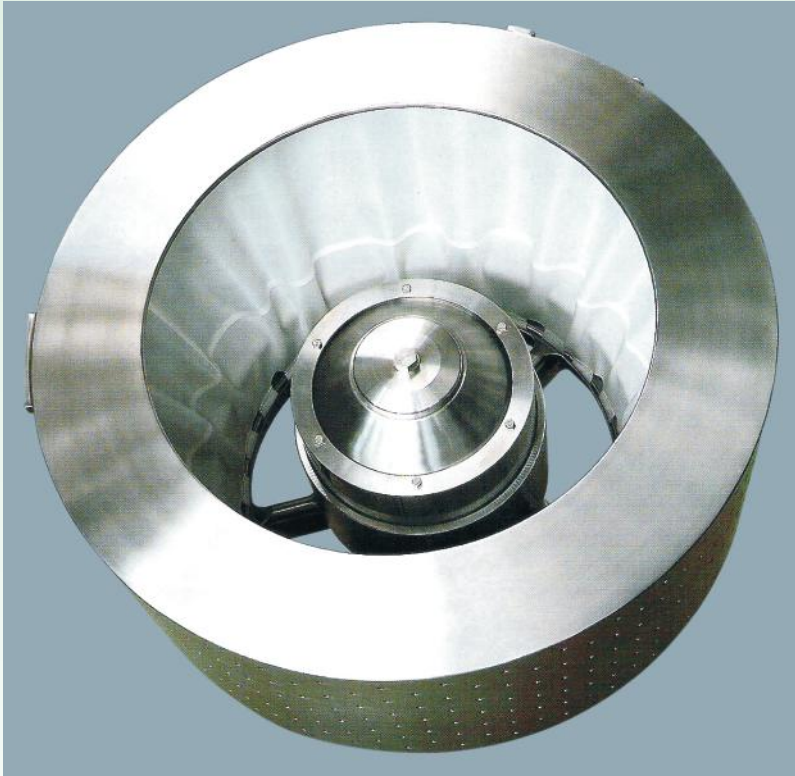

Under Technical Collaboration from **ferrum** Switzerland

Solid Liquid Separation & Cake Washing

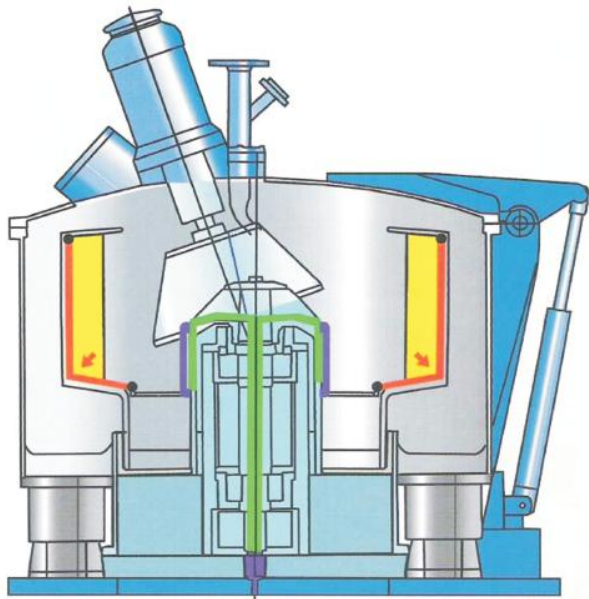

Solids Discharge

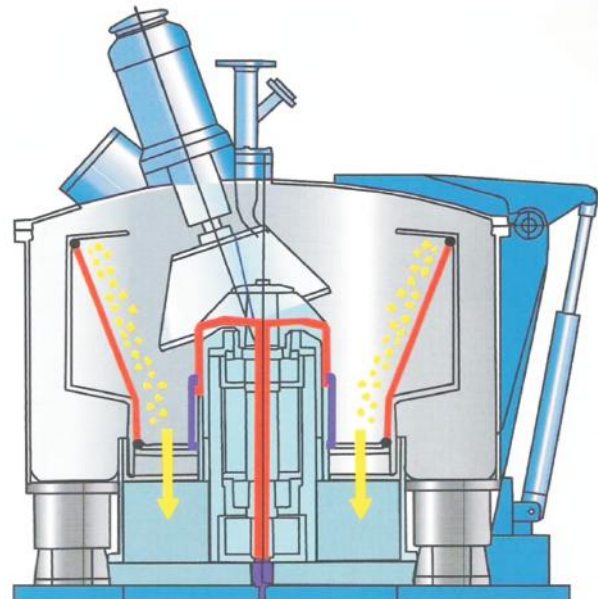

- Bottom Discharge of the Solids by Pulling of the Filter Cloth Pneumatically.
- No Scrapper Required. ● No Heel Remaining.
- Complete Discharge of the Solids in Totally Enclosed Condition.
- Conical Rotating Feeder for uniform slurry distribution & Cake washing.

Technical Data

Type	DZF-R 1000	DZF-R 1250
Basket		
Diameter (mm)	1000	1250
Height (mm)	380	450
Opening Diameter (mm)	700	875
Filtering Area (m ²)	1.19	1.77
Volume (Ltr.)	152.2	281.6
Max. Perm. Load (Kg.)	190.3	352.0
Performances		
Max. Rotation Speed (rpm)	1200	950
Centrifugal Force. (G)	805	631
Basket Effect Empty (kgm ²)	250	680
Basket Effect Loaded (kgm ²)	390	1100
Max. Unbalance (Kg.)	2	3
Motor (kW)		
	18.5	22
Outer Dimensions		
Centrifuge (L x H x W) (Mtr.)	2.0x1.8x 1.9	2.1x1.9x 2.5
H. of the Centrifuge Opened (Mtr.)	2.5	3.1
Net Wight of Centrifuge (Kgs.)		
	3500	5000



SUKHRAS MACHINES PVT. LTD.
(An ISO 9001:2000 Certified Company)

OFFICE: 145, Adarsh Industrial Estate, Sahar Road, Chakala, Andheri (E), Mumbai 400 099. INDIA.
Tel.: 91-22-2832 2721 / 2832 5957/2832 5764. Fax: 91-22-2836 3501.
Email: sukhras@giasbm01.vsnl.net.in, sales@sukhras.com
Website: www.sukhras.com

Factory: Plot No. J-3, M.I.D.C., Tarapur Industrial Area, Boisar, Maharashtra-401 506.
Tel.: (02525) 272614 / 270579 Fax: 272703